



INDUSTRIAL LUBRICATION FITTINGS



- ▶ Threaded/Drive Fittings
- ▶ Corrosion Resistant Fittings
- ▶ Standard/Metric Fittings
- ▶ Specialty Fittings
- ▶ Vents/Breathers
- ▶ Fitting Assortments
- ▶ Fitting Accessories

As the inventor of the Zerk fitting, Alemite is a recognized global leader in supplying fittings for automotive and industrial use. Alemite fittings conform to SAE J534 standards for automotive OEM use, and Alemite's manufacturing is TS/ISO 16949 certified.

- ▶ P.T.F. SAE short taper pipe thread.
- ▶ N.P.T.F. American National taper pipe thread for Dryseal pressure-tight joints.
- ▶ N.P.S.M. American National straight pipe thread for mechanical joints.
- ▶ N.P.S.I. American National straight intermediate pipe thread.



THREADED FITTINGS

1/4"-28 Taper Thread Fittings

ALEMITE 1/4"-28 Taper Thread Fittings are used on most cars and trucks, as well as many industrial machines. It is recommended that SAE-LT taper threads be assembled into 1/4"-28 UNF, Class 3B, straight threaded holes having a modified maximum minor diameter of 0.2151", to ensure 75% minimum thread height.

FEATURES:

- Exceeds 72 hour salt spray test
- Dirt excluding check ball
- Trivalent zinc plating
- RoHS compliant

Product #	Type	Hex Size	Overall Length	Shank Length
1641-B	Straight	5/16"	35/64"	3/16"
1652-B	Straight	5/16"	11/16"	23/64"
1680-B	Straight	5/16"	31/32"	5/8"
1698-B	Straight	5/16"	1-1/8"	25/32"
3014-B	Straight	5/16"	1-5/8"	1"
1637-B1	45°	3/8"	13/16"	13/64"
3010-B1	65°	3/8"	25/32"	19/64"
1911-B1	90°	3/8"	3/4"	13/64"

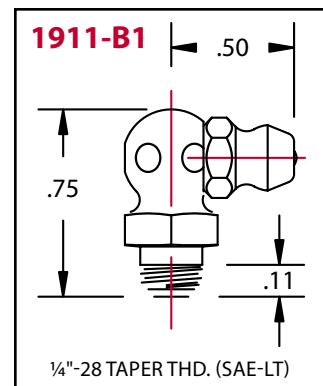
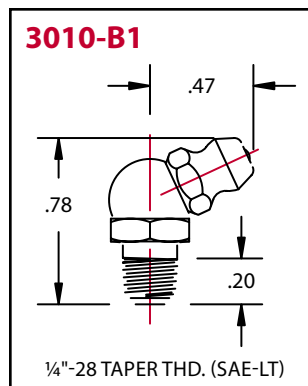
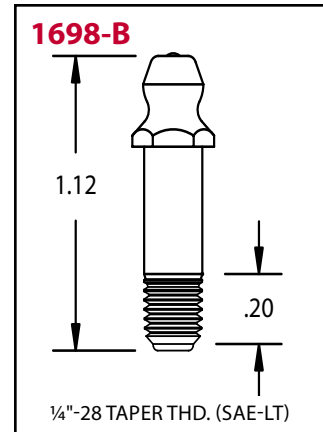
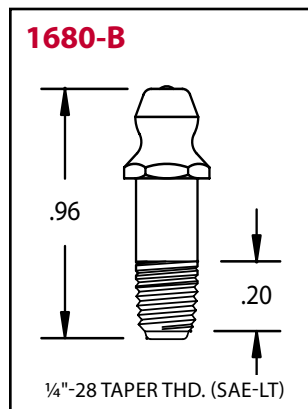
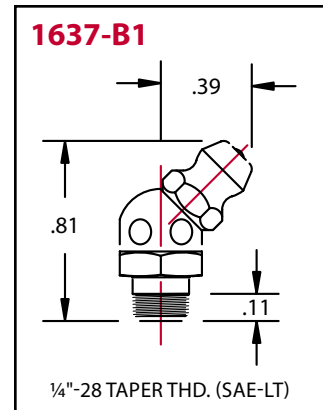
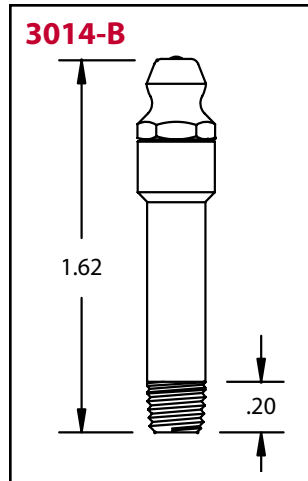
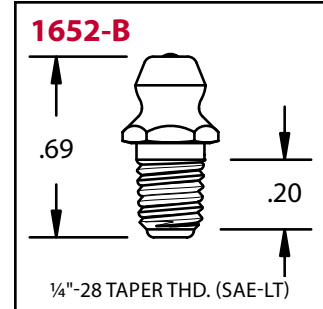
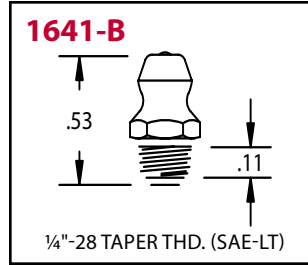

THREADED FITTINGS

1/4"-28 Straight Thread Fittings

Alemite 1/4"-28 Straight Thread Fittings are used on most cars and trucks, as well as many industrial machines.

FEATURES:

- Exceeds 72 hour salt spray test
- Dirt excluding check ball
- Trivalent zinc plating
- RoHS compliant

Product #	Type	Hex Size	Overall Length	Shank Length
1792-B	Straight	9/32"	33/64"	5/32"
1770-B1	45°	3/8"	39/64"	1/8"
369609	Straight	5/16"	7/16"	1/8"

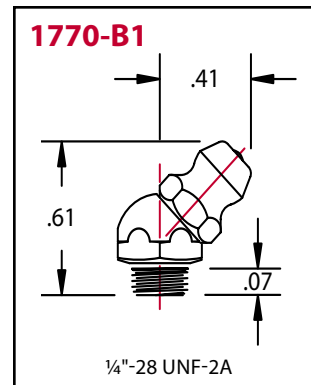
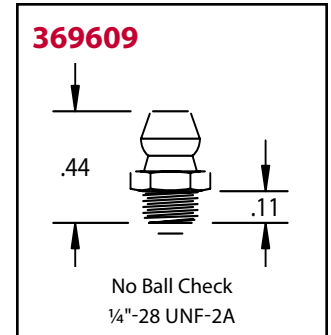
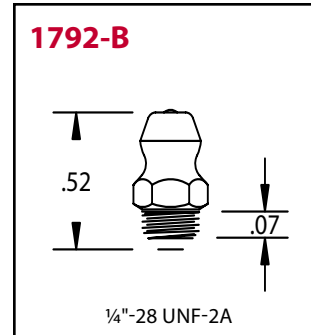



THREADED FITTINGS

1/8" PTF Fittings

Alemite 1/8" PTF Fittings are used on industrial machines and heavy equipment.

FEATURES:

- Exceeds 72 hour salt spray test
- Dirt excluding check ball
- Trivalent zinc plating
- RoHS compliant
- 1958 has specialty cap providing a second seal for dust proof applications

Product #	Type	Hex Size	Overall Length	Shank Length
1644-B	Straight	7/16"	9/16"	15/64"
1610-BL	Straight	7/16"	11/16"	19/64"
1607-B	Straight	7/16"	1-1/4"	25/32"
1669-B	Straight	7/16"	1-3/4"	1-17/64"
1684-B	Straight	3/8"	2-5/8"	2-3/16"
1618-B	Straight	1/2"	1"	9/32"
1958 ⁽¹⁾	Straight	7/16"	31/32"	1/4"
1611-B	30°	7/16"	29/32"	19/64"
1638-B	30°	7/16"	2-3/32"	1-1/4"
1688-B	45°	7/16"	57/64"	19/64"
1620-B	45°	7/16"	1-1/8"	13/32"
1612-B	65°	7/16"	27/32"	19/64"
1623-B	65°	7/16"	1-7/32"	9/16"
1649-B	65°	3/8"	2-3/4"	2-1/4"
1613-B	90°	7/16"	27/32"	19/64"
1606-B	90°	7/16"	1-13/16"	1-1/4"
369599	Straight	7/16"	2-5/8"	7/32"
369608	65°	7/16"	29/32"	9/32"
369574	Double 70°	1/2"	27/32"	7/32"

⁽¹⁾Also available in a 1/8" BSPT version (1958-E)

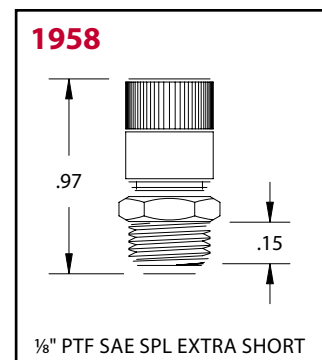
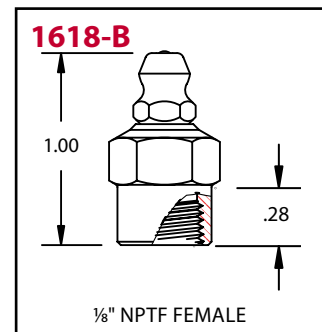
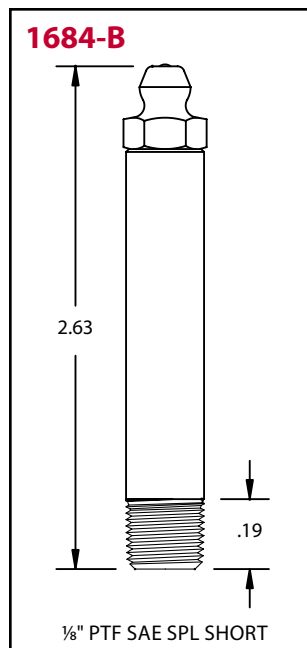
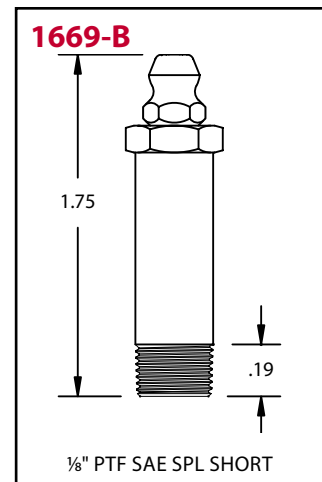
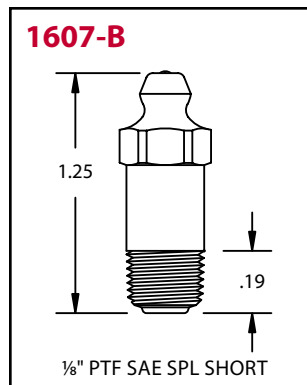
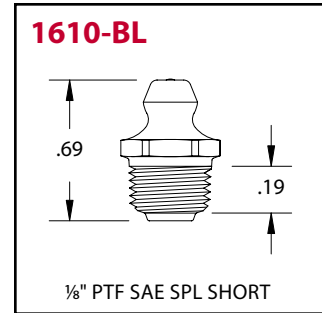
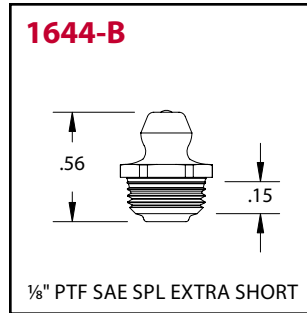

INDUSTRIAL LUBRICATION FITTINGS

THREADED FITTINGS

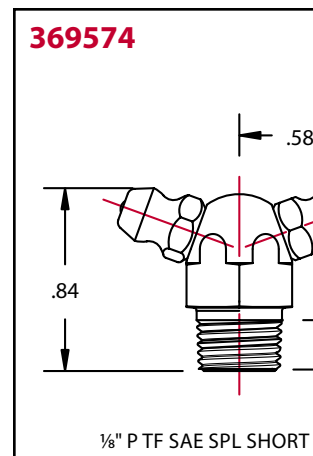
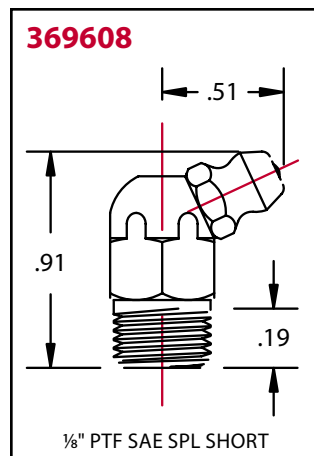
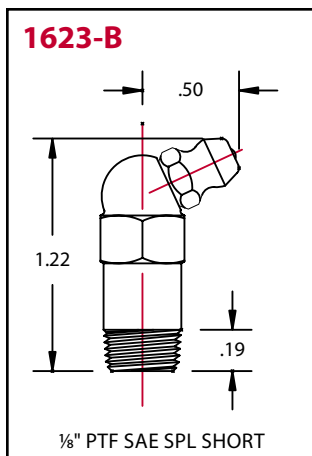
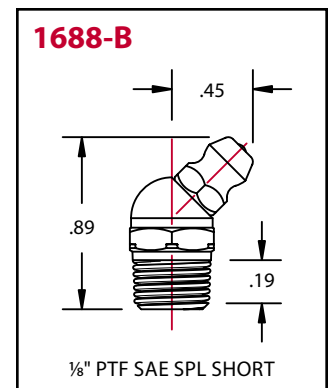
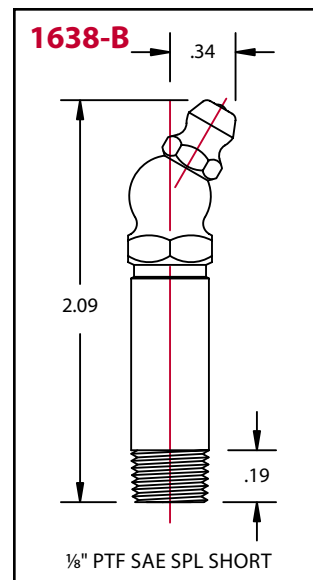
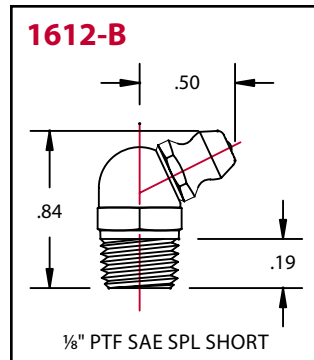
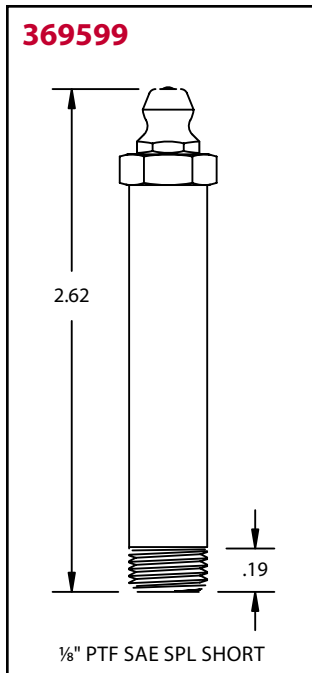
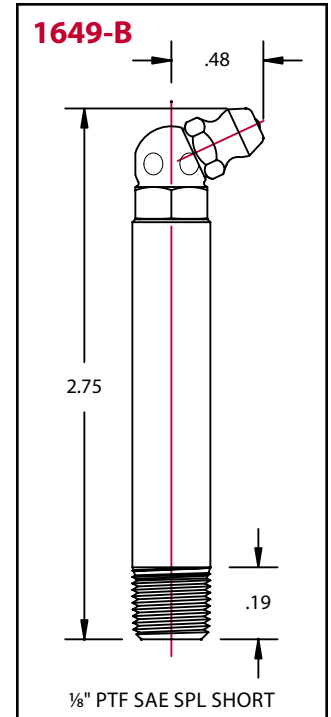
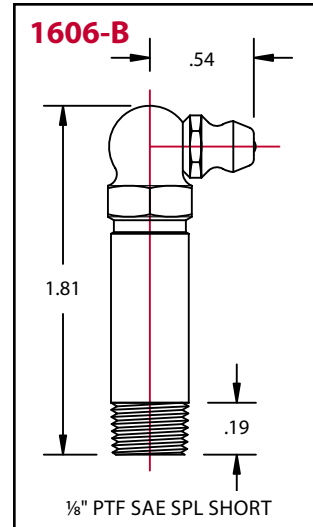
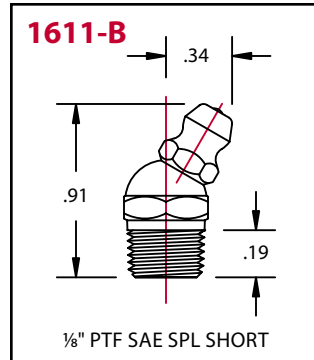
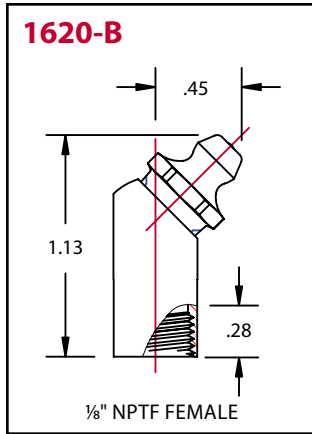



THREADED FITTINGS

1/4" PTF Fittings

Alemite 1/4" PTF Fittings are widely used for larger bearings on farm machinery and heavy industrial equipment. Recommended for heavy lubricants in cold weather.

FEATURES:

- Exceeds 72 hour salt spray test
- Dirt excluding check ball
- Trivalent zinc plating
- RoHS compliant
- Dry seal eliminates need for sealant

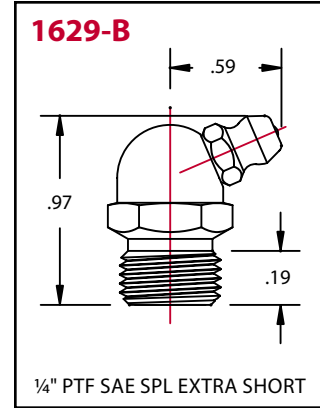
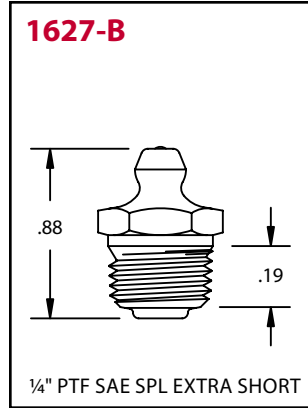

Product #	Type	Hex Size	Overall Length	Shank Length
1627-B	Straight	9/16"	7/8"	27/64"
1629-B	67.5°	9/16"	31/32"	11/32"

INDUSTRIAL LUBRICATION FITTINGS

THREADED FITTINGS

1/4"-28 and 1/8" Thread Forming Fittings

Alemite Thread Forming Fittings have special tapered drive threads which reshape the material in an untapped hole to provide a leak proof seal. They are most effectively installed by spinning into the untapped hole. Thread forming fittings can be replaced by any standard threaded fitting or by another thread forming fitting.

FEATURES:

- Exceeds 72 hour salt spray test
- Dirt excluding check ball
- Threads provide strong seal
- Dyed yellow for identification
- Trivalent zinc plating
- RoHS compliant

Product #	Type	Hex Size	Hole Size recommended
3038-B	Straight	5/16"	.230 - .235
3053-B	45°	3/8"	.230 - .235
3054-B	90°	3/8"	.230 - .235
1720-B	Straight	7/16"	.373 - .380
1723-B	90°	7/16"	.373 - .380
1724-B	45°	7/16"	.373 - .380
369582	Straight	9/32"	.230 - .235

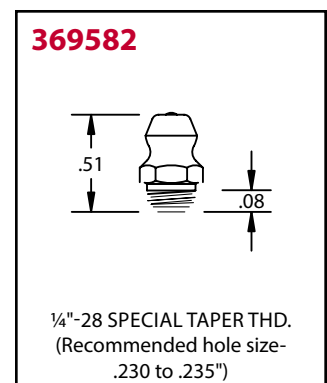
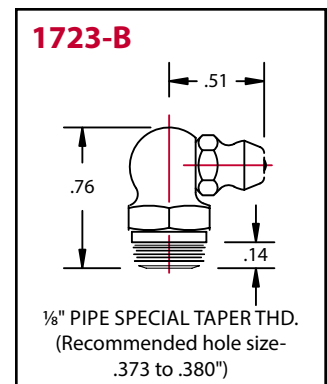
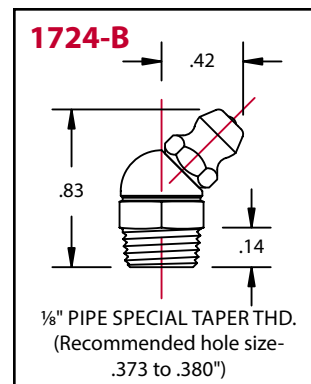
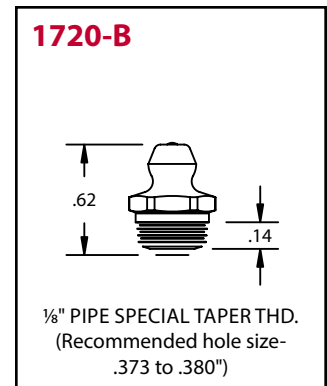
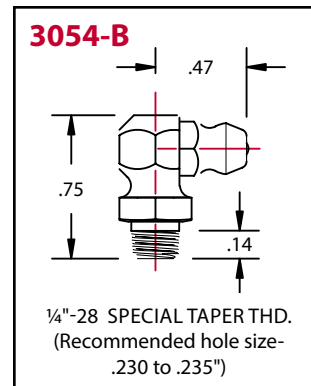
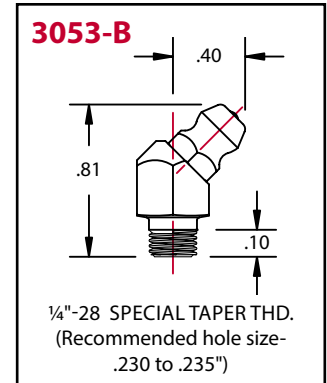
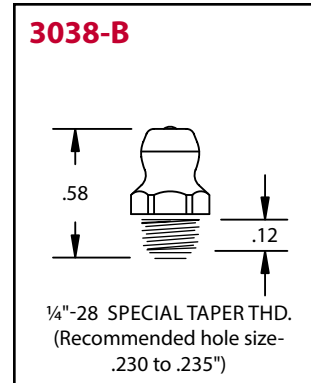

CORROSION RESISTANT FITTINGS

Monel Fittings

Alemite Monel Fittings withstand the most severe marine and industrial corrosive environments. Monel is a Nickel/Copper alloy that is highly resistant to corrosion. All monel fittings have a single notch on the hex for easy identification.

FEATURES:

- Greater corrosion resistance than stainless steel
- Withstands extreme temperatures ranging from sub-zero to 700°F (371°C)
- Ideal for use in harsh chemical environments and marine applications
- Dirt excluding check ball
- RoHS compliant

Product #	Thread	Type	Hex Size	Overall Length	Shank Length
1966-B	1/4"-28 Taper	Straight	5/16"	17/32"	3/16"
1969-B	1/4"-28 Taper	90°	3/8"	3/4"	13/64"
1962-B	1/8" PTF	Straight	7/16"	5/8"	9/32"
1961-B	1/8" PTF	Straight	7/16"	3/4"	5/16"
1921-B	1/8" PTF	30°	7/16"	1-1/4"	11/32"
1922-B	1/8" PTF	67.5°	7/16"	61/64"	11/32"
1923-B	1/8" PTF	90°	7/16"	7/8"	11/32"

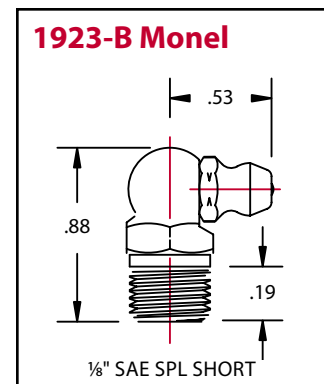
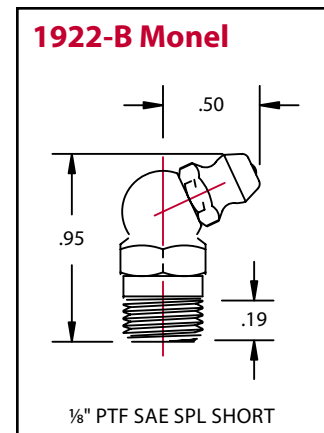
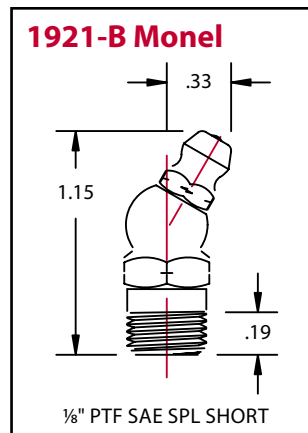
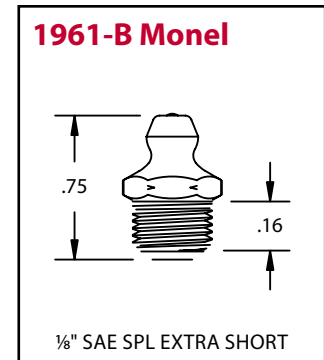
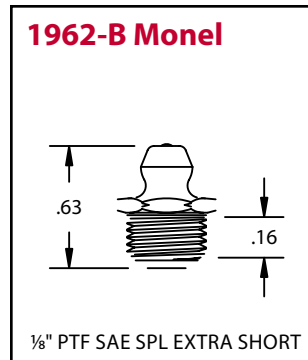
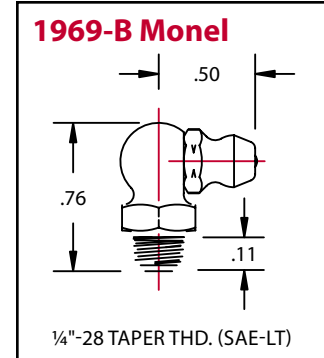
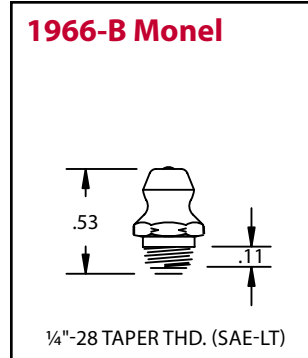

INDUSTRIAL LUBRICATION FITTINGS

CORROSION RESISTANT FITTINGS

Stainless Steel Fittings

Alemite Stainless Steel Fittings withstand severely corrosive marine and industrial environments. All stainless steel fittings have 2 notches for easy identification.

FEATURES:

- Greater corrosion resistance than carbon steel
- Withstands extreme temperatures ranging from sub-zero to 600°F (315°C)
- Ideal for use in harsh chemical environments and marine applications
- Stainless steel fittings are comprised of Type 303 SS for fitting bodies, Type 440 SS for balls, and Type 302 for tempered springs
- Dirt excluding check ball
- RoHS compliant

Product #	Thread	Type	Hex Size	Overall Length	Shank Length
1966-S	1/4"-28 Taper	Straight	5/16"	17/32"	3/16"
1968-S	1/4"-28 Taper	45°	3/8"	13/16"	13/64"
1969-S	1/4"-28 Taper	90°	3/8"	3/4"	13/64"
1961-S	1/8" PTF	Straight	7/16"	3/4"	5/16"
1921-S	1/8" PTF	30°	7/16"	1-1/4"	11/32"
1922-S	1/8" PTF	67.5°	7/16"	61/64"	11/32"
1923-S	1/8" PTF	90°	7/16"	7/8"	11/32"
1728-S	Drive	Straight	5/16"	33/64"	5/16"

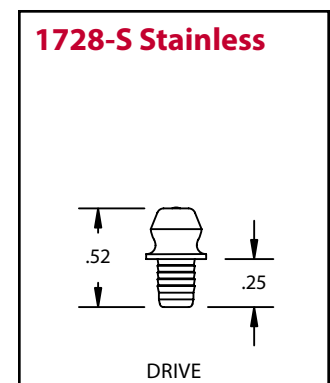
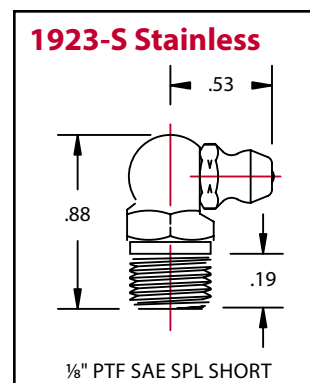
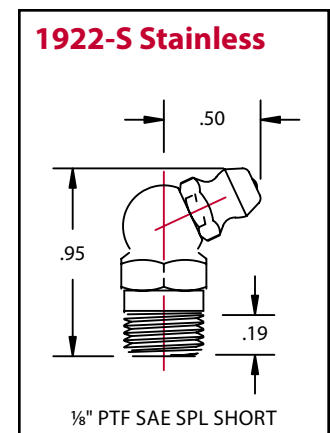
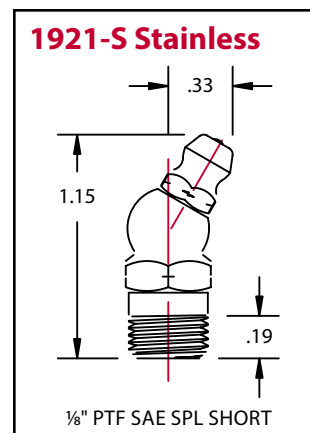
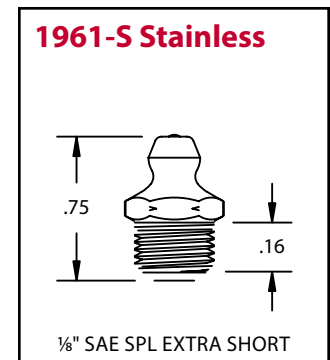
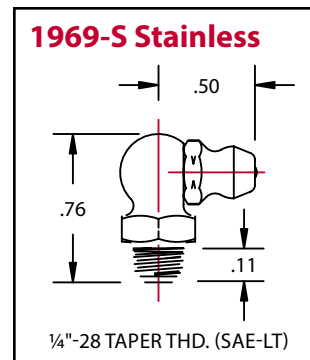
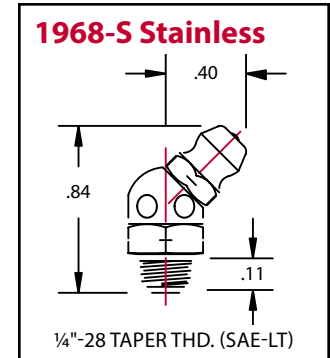
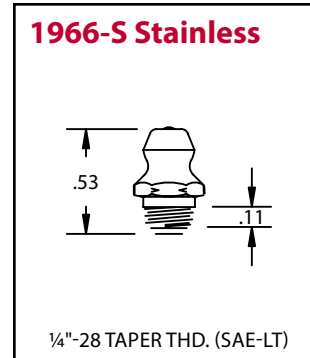

DRIVE FITTINGS

Straight

Alemite Drive Fittings provide a simple, cost effective alternative to tapping for various applications.

FEATURES:

- Exceeds 72 hour salt spray test
- Used for untapped holes
- Serrated shank provides secure, lasting grip
- Simplifies replacement of damaged fittings in old or oversized holes
- Trivalent zinc plating
- RoHS compliant

All fittings clear zinc unless otherwise noted.

Product #	Type	Overall Length	Shank Length	Drill Diameter	Ball Check
1736-A	Straight	9/16" (14.28 mm)	1/4"	1/8"	No
3019	Straight	15/32" (11.91 mm)	5/32"	1/8"	No
3009	Straight	25/64" (9.92 mm)	3/32"	3/16"	No
3005	Straight	15/32"	11/64"	3/16"	No
3006	Straight	31/64"	7/32"	3/16"	No
1728-B	Straight	33/64" (13.09 mm)	1/4"	3/16"	Yes
1633	Straight	5/8"	1/4"	3/16"	No
1743-B	Straight	35/64"	1/4"	1/4"	Yes
1952-A	Straight	15/32"	1/8"	1/4"	No
1608-B	Straight	35/64" (13.89 mm)	1/4"	5/16"	Yes
1666	Straight	37/64"	7/32"	3/8"	No
369591	Straight	21/50"	–	3/16"	No
369604	Straight Flush	11/32" (8.73 mm)	21/64"	1/4"	Yes
369577 ⁽¹⁾	Straight	35/64" (13.89 mm)	1/4"	1/4"	Yes

⁽¹⁾Yellow zinc

Drive Fitting Tools-Straight

Product #	Type of Drive Fitting	Use with Fitting
5253	Straight	1633, 1666, 1720-B, 1736-A, 1952-A, 3005, 3009, 3019, 369591, 369604, 369577
5253-1	Straight	1608-B, 1743-B, 3038-B
5253-3	Straight	1728-B



5253

INDUSTRIAL LUBRICATION FITTINGS

DRIVE FITTINGS

Angled

Alemite Drive Fittings provide a simple, cost effective alternative to tapping for various applications.

FEATURES:

- Exceeds 72 hour salt spray test
- Used for untapped holes
- Serrated shank provides secure, lasting grip
- Simplifies replacement of damaged fittings in old or oversized holes
- Trivalent zinc plating
- RoHS compliant

Product #	Type	Overall Length	Shank Length	Drill Diameter	Ball Check
1992-B1	45°	53/64"	7/32"	3/16"	Yes
1646-B1	65°	45/64"	7/32"	3/16"	Yes
1744-B1	65°	49/64"	9/32"	1/4"	Yes
1630-B1	65°	45/64"	7/32"	5/16"	Yes

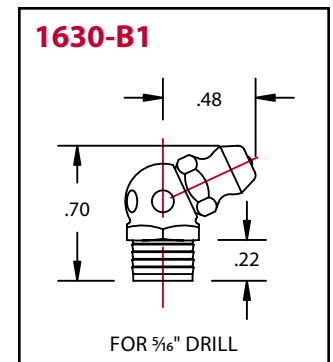
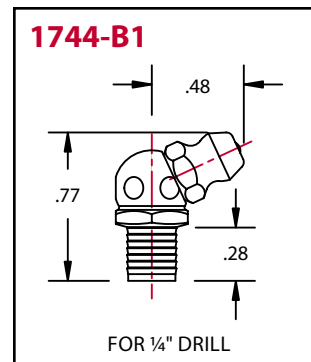
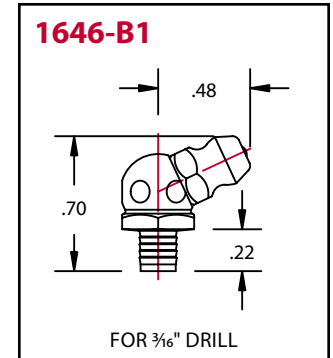
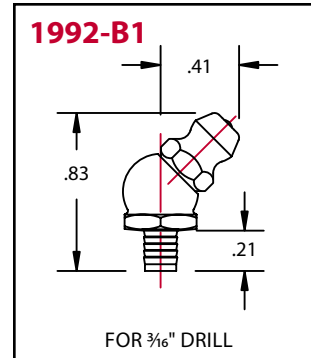

Drive Fitting Tools-Angled

This special tool simplifies the original installation of drive fittings in untapped holes.

Product #	Type of Drive Fitting	Use with Fitting
5254-1	Angled	1630-B1, 1646-B1, 1744-B1, 1992-B1, 1722-B, 1723-B, 1724-B





METRIC FITTINGS

Threaded Metric Fittings

Alemite metric thread conforms to German Standard DIN 71412.

FEATURES:

- Exceeds 72 hour salt spray test
- Dirt excluding check ball
- Trivalent zinc plating
- RoHS compliant

Prod. #	Thread	Type	Hex Size	Overall Length	Shank Length
2106	6 mm x 1 mm	Straight	7 mm	19/32"	1/4"
2107	6 mm x 1 mm	45°	10 mm	13/16"	7/32"
2108	6 mm x 1 mm	90°	10 mm	3/4"	7/32"
2103	8 mm x 1 mm	Straight	9 mm	5/8"	1/4"
2105	8 mm x 1 mm	90°	10 mm	3/4"	7/32"
2109	10 mm x 1 mm	Straight	11 mm	5/8"	1/4"

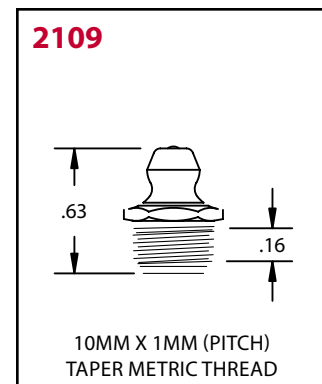
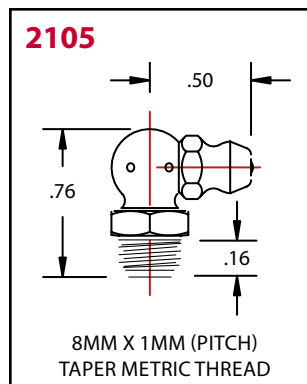
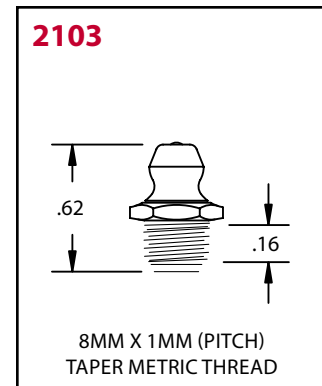
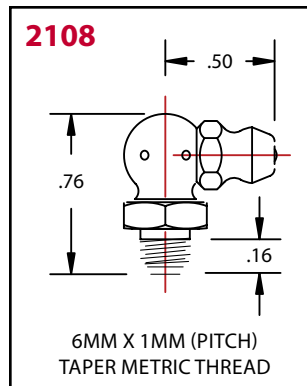
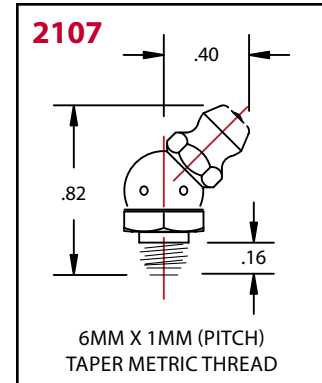
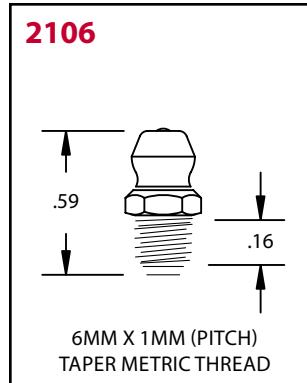

INDUSTRIAL LUBRICATION FITTINGS

BUTTON HEAD FITTINGS

Standard

Alemite Standard Button Head Fittings are used in rugged applications such as heavy machinery, construction equipment and off road equipment.

FEATURES:

- Exceeds 72 hour salt spray test
- Trivalent zinc plating
- RoHS compliant
- Head size helps minimize breakage
- Dirt excluding plunger check valve helps reduce dirt contamination

Product #	Thread	Hex Size	Overall Length	Shank Length
A1184	1/8" PTF	5/8"	3/4"	11/32"
A1186	1/4" NPTF	5/8"	53/64"	27/64"
A1188	3/8" NPTF	3/4"	61/64"	31/64"
A1190	1/2" NPTF	7/8"	1-1/16"	35/64"
C69	1/8" NPTF(f)	5/8"	31/32"	13/32"
M1184	1/8" PTF	5/8"	3/4"	11/32"

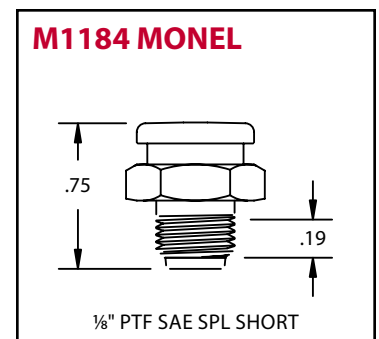
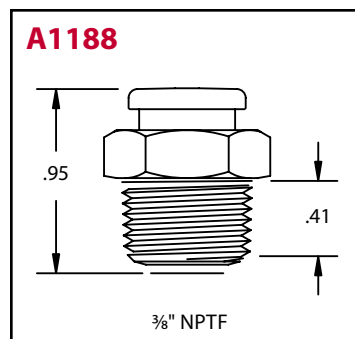
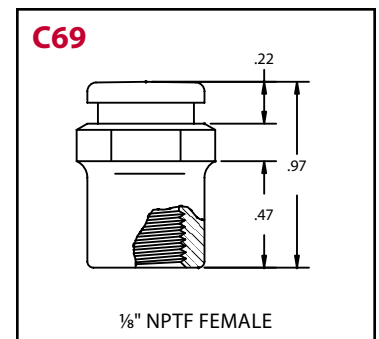
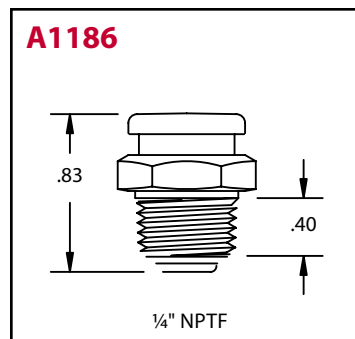
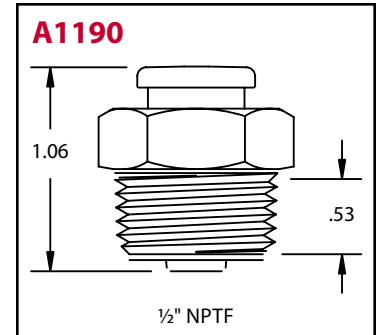
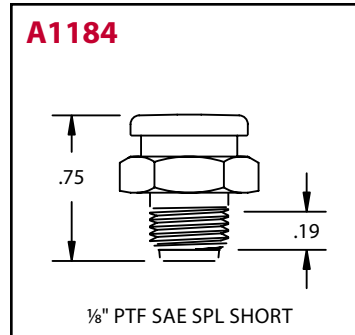



BUTTON HEAD FITTINGS

Giant Fittings

Alemite Giant Button Head Fittings are the largest fitting available for rugged applications.

FEATURES:

- Exceeds 72 hour salt spray test
- Trivalent zinc plating
- RoHS compliant
- Head size helps minimize breakage
- Dirt excluding plunger check valve helps reduce dirt contamination

Product #	Thread	Hex Size	Overall Length	Shank Length
1823-1	1/4" NPTF	7/8"	1-1/4"	1/2"
1822-A1	3/8" NPTF	7/8"	1-5/16"	9/16"
1820-1	1/2" NPTF	7/8"	1-1/16"	1/2"

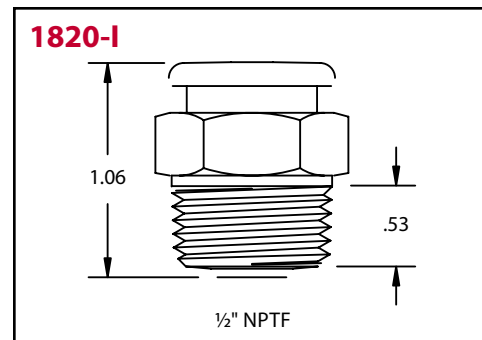
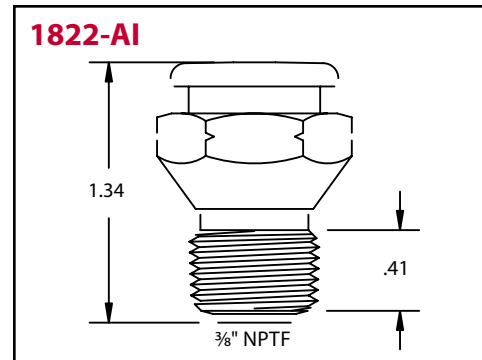
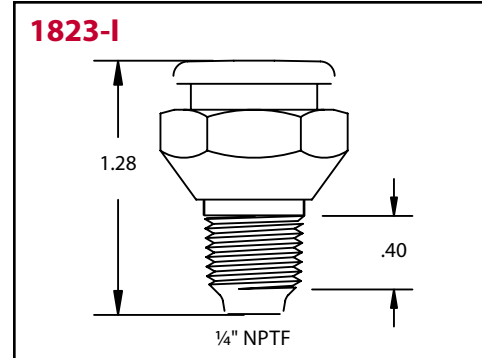

INDUSTRIAL LUBRICATION FITTINGS

RELIEF FITTINGS

Alemite Relief Fittings are used on gearbox housings and bearings (king pins, universal joints, etc.) where excessive lubrication pressure is not desired.

FEATURES:

- Exceeds 72 hour salt spray test
- Trivalent zinc plating
- RoHS compliant
- Fittings open at predetermined pressure (see table)
- May be used with grease or oil
- 338382 is a leak proof fitting

RECOMMENDED ACCESSORIES

- 1/8" – 1/4" Bushing (45120)

British Standard Pipe Thread Fittings

FEATURES:

- Dirt excluding check ball
- Trivalent zinc plating
- RoHS compliant

Product #	Description	Opening Pressure
317400-E	1/8" BSPT Relief Fitting	1/4 to 1 psi
47200-E	1/8" BSPT Relief Fitting	1 to 5 psi
47100-E	1/8" BSPT Relief Fitting	45 to 80 psi

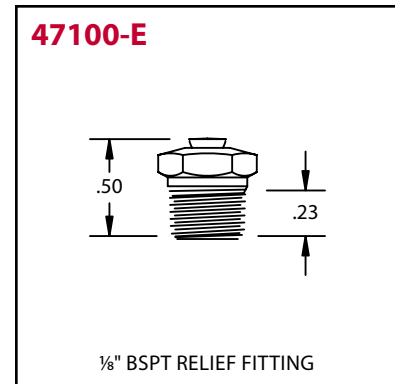



RELIEF FITTINGS

1/8" Pipe Thread

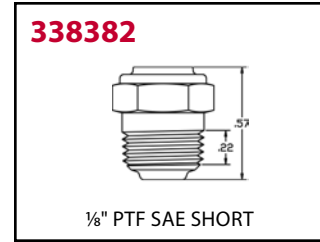
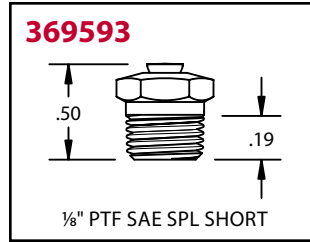
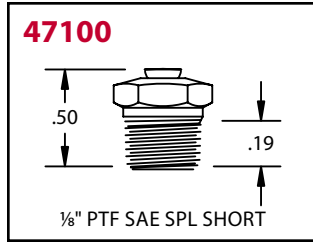

Product #	Thread	Relief Pressure		Pressure Based on Using Air/Grease/Oil
		Min	Max	
317400	1/8" PTF SAE SPL Short	.25 psi	1 psi	Air at 1.2 Ft3/Hr
47200	1/8" PTF SAE SPL Short	1 psi	5 psi	Oil 30W SAE
47640	1/8" PTF SAE SPL Short	7.5 psi	15 psi	Oil 30W SAE
323060	1/8" PTF SAE SPL Short	15 psi	25 psi	Oil 30W SAE
47100	1/8" PTF SAE SPL Short	45 psi	80 psi	Oil 30W SAE
50500	1/8" PTF SAE SPL Short	400 psi	650 psi	NLGI 1 Grease, Calcium Based
369593	1/8" PTF SAE SPL Short	100 psi	200 psi	NLGI 1 Grease, Calcium Based
338382	1/8" PTF SAE SPL Short	80 psi	140 psi	Oil 30W SAE

Drive

Product #	Drive Fitting	Relief Pressure	
		Min	Max
321839	3/8" Diameter Drill	1 psi	5 psi

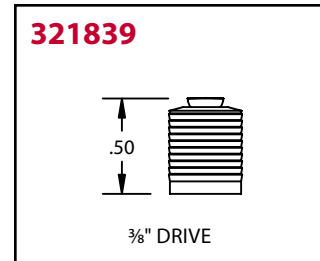

INDUSTRIAL LUBRICATION FITTINGS

FLUSH TYPE FITTINGS

Alemite Flush Type Fittings are used where protruding fittings are not desirable, such as for line shafting pulleys or revolving bearings.

FEATURES:

- Exceeds 72 hour salt spray test
- Dirt excluding check ball
- Trivalent zinc plating
- RoHS compliant
- Flush mounting reduces potential for damage

Threaded - Slotted

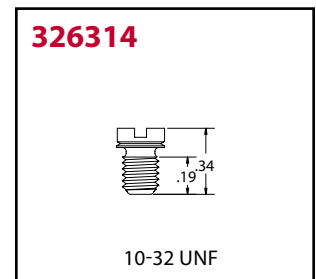
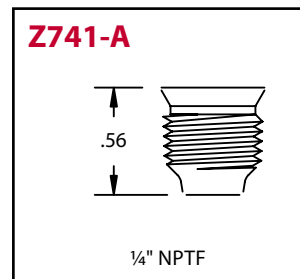
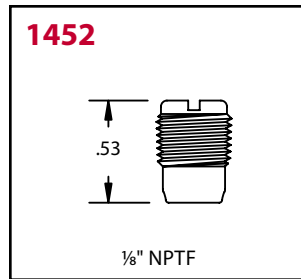
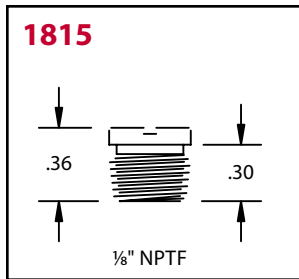

Product #	Thread	Type	Overall Length	Shank Length	Drill Diameter
1815	Overall Length	Slotted	Shank Length	19/64"	—
1452	Overall Length	Slotted	Shank Length	—	—
Z741-A	Overall Length	Slotted	Shank Length	—	—
326314	10-32 UNF	Slotted	3/8"	15/64"	—



FLUSH TYPE FITTINGS

Threaded - Hex

Product #	Thread	Type	Overall Length	Shank Length	Drill Diameter
1851	1/4"-28 NF	Hex	13/32"	19/64"	—

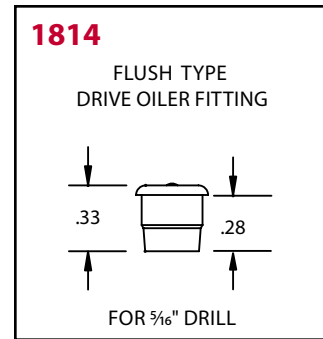
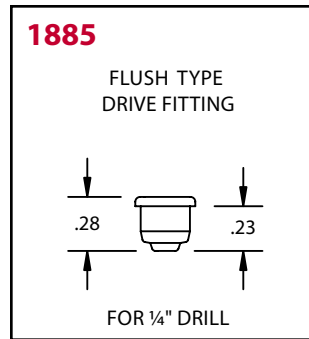
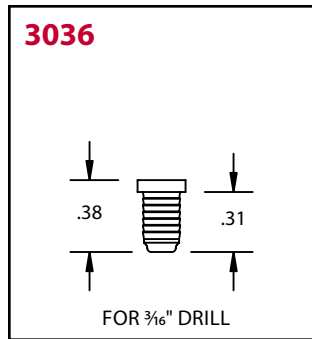
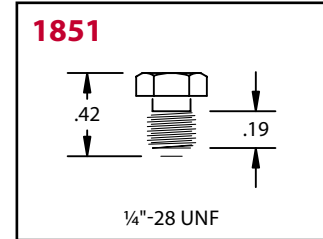

Drive

Product #	Thread	Type	Overall Length	Shank Length	Drill Diameter
3036	Drive	Straight	3/8"	5/16"	3/16"
1885	Drive	Straight	9/32"	15/64"	1/4"
1814	Drive	Straight	21/64"	9/32"	5/16"

INDUSTRIAL LUBRICATION FITTINGS

LEAKPROOF FITTINGS

To improve reliability of the check valve in these fittings, keep input passages free of foreign particles. Redundancy of seal should be provided in critical applications where back pressure must be maintained.

Threaded

RECOMMENDED ACCESSORY:

- Dust Caps

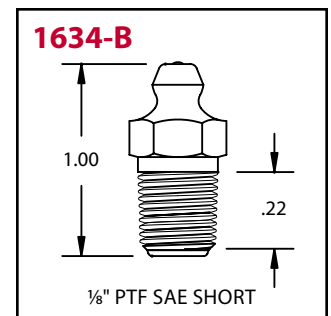
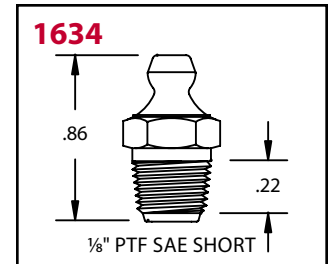
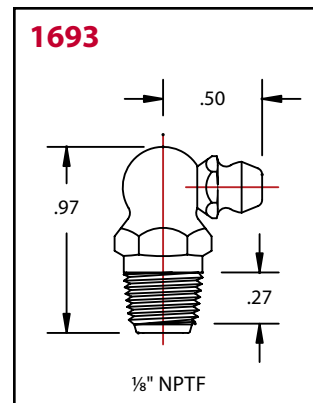
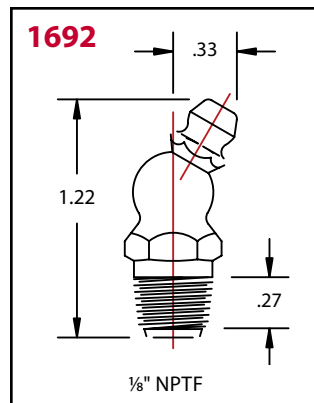
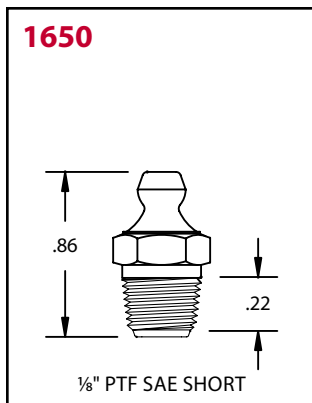

Product #	Type	Thread	Hex Size	Overall Length	Shank Length	Check Valve	Max. Back Pressure
1650 ⁽¹⁾	Straight	1/8" PTF SAE Short	7/16"	29/32"	25/64"	Fluoroelastomerer Ball	3,000 psi
1692 ⁽¹⁾	30°	1/8" NPTF	7/16"	1-7/32"	25/64"	Buna-N disk	3,000 psi
1693 ⁽¹⁾	90°	1/8" NPTF	7/16"	31/32"	25/64"	Buna-N disk	3,000 psi
1634 ⁽²⁾	Straight	1/8" PTF SAE Short	7/16"	27/32"	23/64"	Steel Ball/Brass Seat	10,000 psi
1634-B ⁽²⁾	Straight	1/8" PTF SAE Short	7/16"	1"	33/64"	Steel Ball/Brass Seat plus dirt excluding surface ball check	10,000 psi

⁽¹⁾ Designed for light oils

⁽²⁾ Designed for grease, medium and heavy oils

Drive

Product #	Type	Thread	Press Fit OD	Overall Length	Check Valve	Max Back Pressure
369533	Straight	—	7/16"	55/64"	Steel Ball/Brass Seat	*

* Maximum pressure depends on the press fit

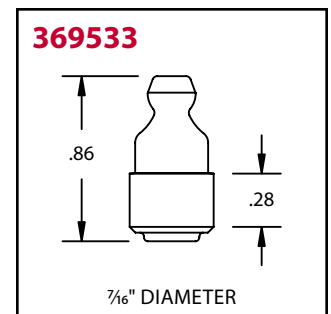



VENTS

Vents

Alemite Vents are used with transmissions, speed reducers, axles, gear housings and similar applications. The vent is placed above normal lubrication level to allow air to escape when internal pressure rises.

FEATURES:

- Exceeds 72 hour salt spray test
- Trivalent zinc plating
- Vent opens at designated pressure (see table)
- Helps to prevent fluid leakage
- Special cap prevents water or dirt from entering

Product #	Thread	Opening Pressure
300805	1/8" PTF SAE Short	Felt filter
304810	1/8" PTF SAE Short	1-3" water
324970	Drive 3/8". Designed as 0.374 ±0.000-0.003 drive. Use 0.368" drill or U drill.	6-12" water, 0.25 to 0.43 psi
131000-T	1/8" PTF SAE Short	12" water max
327240	1/8" PTF SAE Short	1 to 1-1/2 psi
330766	1/8" PTF SAE Short	2-1/2 to 4 psi
369622	1/8" PTF SAE Special Short	2-1/2 to 4 psi
369602	1/8" PTF SAE Short	1 to 2 psi

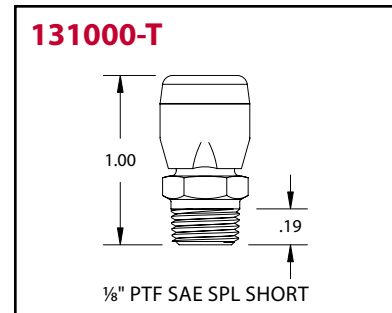
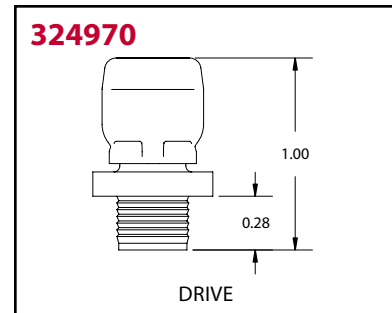
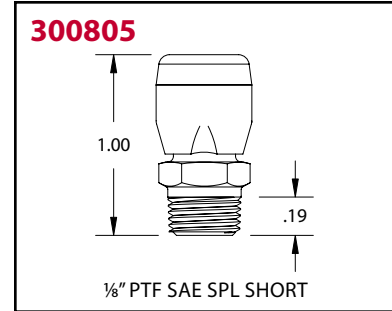

INDUSTRIAL LUBRICATION FITTINGS

BREATHERS

Breathers

Alemite Breathers are used with transmissions, differentials, speed reducers, axles, gear housings and similar applications. The breather helps maintain proper pressure.

FEATURES:

- Exceeds 72 hour salt spray test
- Trivalent zinc plating
- No airflow restrictions
- Breathers with felt filters help reduce dirt contamination

Product #	Description	Thread
313650	Two Baffles	3/8" PTF SAE Short
369583 ⁽¹⁾	Corrosion Resistant	1/8" PTF SAE Short
369528	Press Fit, Two Baffles	Goes into .497/.5032 DIA hole
321620	Zinc Trivalent	1/8" PTF SAE SPL Short
369518	Double Vent	Drive 0.374±0.000-0.003 hole Use 0.36" drill or U drill
369568	M 10 x 1.5	M 10 x 1.5

⁽¹⁾ 240 hour salt spray test

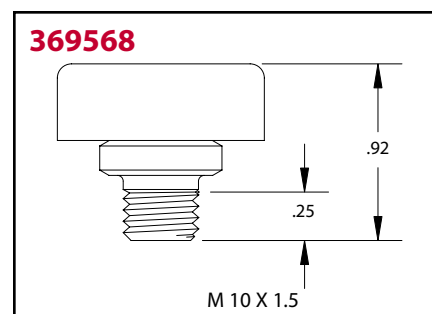
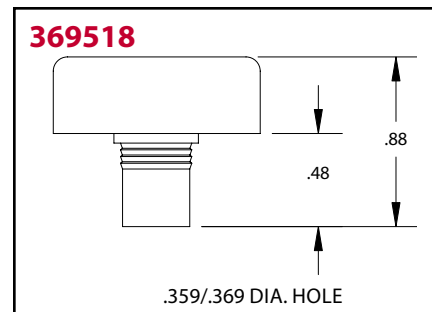
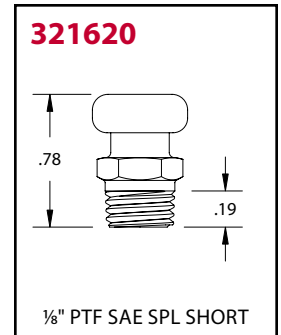
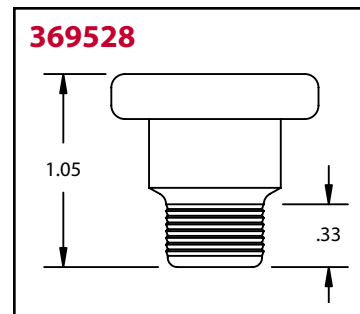
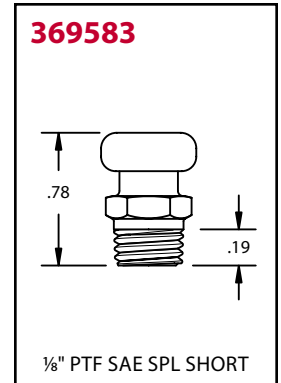
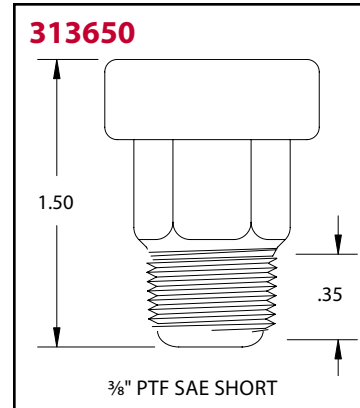



SPECIALTY FITTINGS

Special Thread Fittings

Alemite offers special threads and sizes for special lubrication applications. All have high pressure ball check unless noted.

FEATURES:

- Exceeds 72 hour salt spray test
- Dirt excluding check ball
- Trivalent clear zinc plating
- RoHS compliant
- 3016, 3018 and 369616 have no ball check

Product #	Thread	Type	Hex Size	Overall Length	Shank Length
3016	10-32 UNF-2A	Straight	1/4"	1/2"	1/8"
3018	6-40 UNF-2A	Straight	1/4"	1/2"	9/64"
1711-B	5/16"-24 UNF-2A	Straight	3/8"	21/32"	5/32"
1631-B	5/16"-32 UNEF-2A	Straight	3/8"	21/32"	15/64"
1648-B1	5/16"-32 UNEF-2A	65°	3/8"	51/64"	7/32"
369616	10-32 UNF-2A	Straight	1/4"	15/32"	5/64"

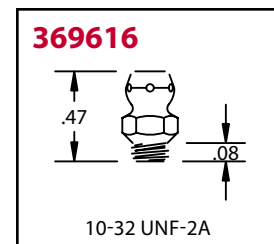
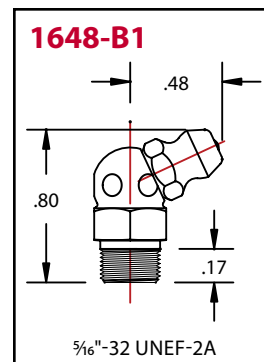
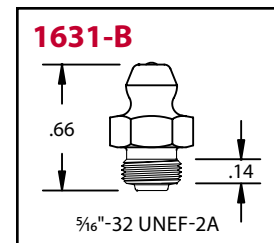
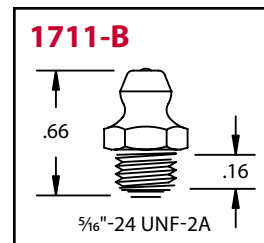
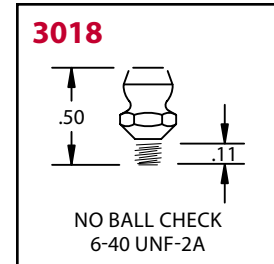
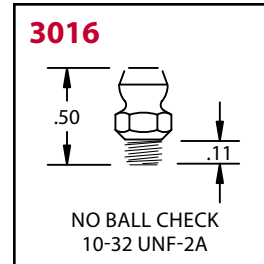

INDUSTRIAL LUBRICATION FITTINGS

SPECIALTY FITTINGS

Rivet Fittings

Alemite Rivet Fittings are used where threaded or drive fittings are difficult to use. They are commonly used for king pin applications.

FEATURES:

- Exceeds 72 hour salt spray test
- Dirt excluding check ball
- Trivalent zinc plating
- RoHS compliant

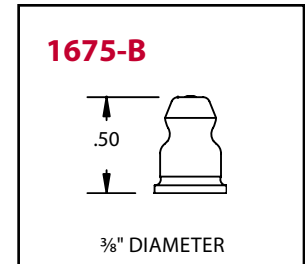

Product #	Type	Overall Length	Fitting Diameter	Rivet Diameter
1675-B	Straight	1/2"	3/8"	5/16"

Pin Type Fittings

Alemite Pin Type Fittings have positive locking action on coupler and cross pin, providing a leakproof connection.

FEATURES:

- Exceeds 72 hour salt spray test
- Dirt excluding check ball
- Trivalent zinc plating
- RoHS compliant

RECOMMENDED ACCESSORIES:

- Pin Type Couplers (VB942, 50491, 51185)

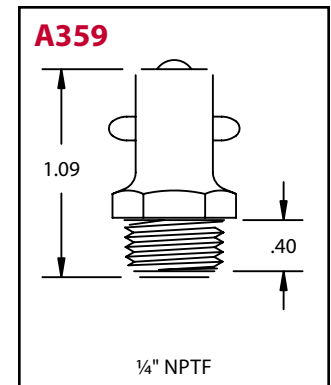
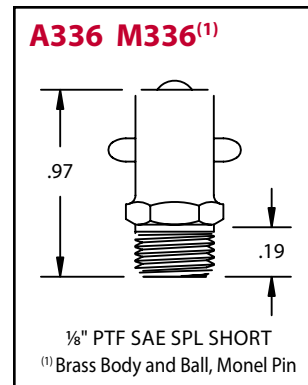

Product #	Thread	Type	Hex Size	Overall Length	Shank Length
A336*	1/8" PTF	Straight	7/16"	31/32"	17/64"
A359*	1/4" NPTF	Straight	17/32"	1-3/32"	5/16"
M336*	1/8" PTF	Straight	7/16"	31/32"	17/64"

*  **WARNING** California Proposition 65: Cancer and reproductive harm. www.P65Warnings.ca.gov

SPECIALTY FITTINGS

Hydraulic Shut Off Fittings

Alemite Hydraulic Shut Off Fittings positively shut off at specified pressure, preventing over-lubrication and damaging of bearing seals.

FEATURES:

- Exceeds 72 hours salt spray test
- Dirt excluding check ball
- Trivalent zinc plating
- RoHs compliant

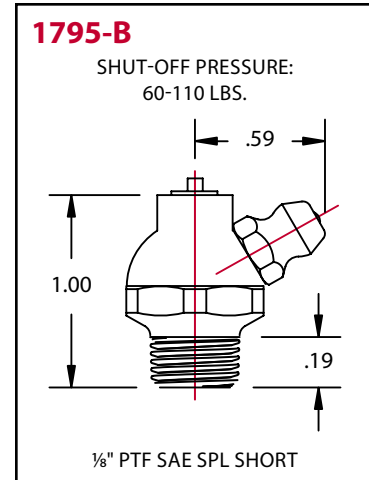
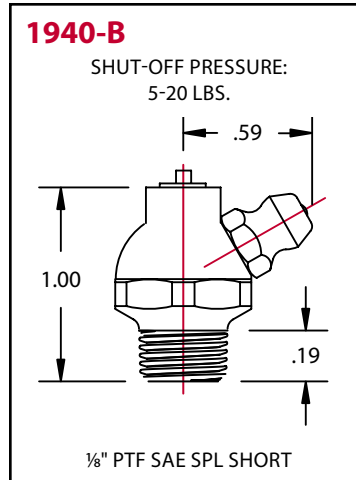

Product #	Type	Hex Size	Overall Length	Shank Length	Shutt-off Pressure
1940-B	60°	5/8"	1"	17/64"	5-20 psi
1795-B	60°	5/8"	1"	17/64"	60-110 psi

Bullet Nose Fitting

Product #	Thread	Type	Hex Size	Overall Length
369613	1/4"-28 SAE-LT	Straight	0.28"	0.51"

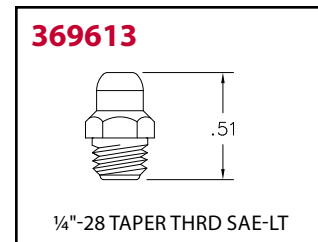



INDUSTRIAL LUBRICATION FITTINGS

FITTING ASSORTMENTS

Blister Packs

Alemite Blister Packs are packaged for display or easy storage. Each pack contains 10 fittings unless otherwise noted.

Product #	Type	Hex Size	Overall Length	Shank Length	Quantity
B1610-BL	Straight	7/16"	11/16"	19/64"	10
B1611-B	30°	7/16"	29/32"	19/64"	10
B1613-B	90°	7/16"	27/32"	19/64"	10
B1627-B	Straight	9/16"	7/8"	27/64"	5
B1629-B	67.5°	9/16"	31/32"	11/32"	5
B1637-B1	45°	3/8"	13/16"	13/64"	10
B1641-B	Straight	5/16"	35/64"	3/16"	10
B1688-B	45°	7/16"	57/64"	19/64"	10
B1911-B1	90°	3/8"	3/4"	13/64"	10
B2103	Straight	9 mm	5/8"	1/4"	10
B2105	90°	10 mm	3/4"	7/32"	10
B2106	Straight	7 mm	19/32"	1/4"	10
B2108	90°	10 mm	3/4"	7/32"	10
B2109	Straight	11 mm	5/8"	1/4"	10



FITTING ASSORTMENTS

Multiple Size Assortments - Standard

Alemite Standard Fitting Assortments include a selection of popular standard sized fittings.

FEATURES:

- All Purpose Fitting Assortment (2364-1) includes 2 tools for extracting fittings and rethreading holes
 - B315790 – 1/4"-28 Fitting Tool
 - B315791 – 1/8" PTF Fitting Tool



2364-1



2365-1

Product #	Description	1610-BL	1688-B	1613-B	1641-B	1637-B1	1911-B1	1611-B	1612-B
2398-1	Vehicle Fitting Assortment	24	12	12	24	12	12	–	–
2364-1	All Purpose Fitting Assortment	36	12	12	24	12	12	12	12
2365-1	Pocket Pack Fitting Assortment	12	6	6	12	6	6	–	–

Multiple Size Assortments - Metric

Alemite Metric Fitting Assortments include a selection of metric fittings.



2371

Product #	Description	2106	2107	2108	2103	2105	2109
2371	Metric Fitting Assortment	10	6	6	6	6	10